

A

B

C

D

E

REVISION HISTORY

REV	BY	RELEASE DATE	DESCRIPTION	ORIGINATOR	CHANGE ORDER
A	EM	3/29/19	FIRST RELEASE	EM	4900

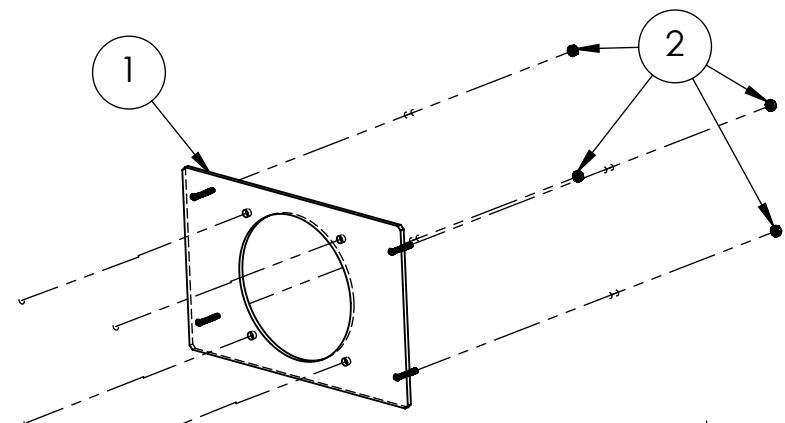

② Zinc-Plated Steel Locknut with External-Tooth Lock Washer, 6-32 Thread Size, 1/4" Wide

③ INSERT 4 PEM STUDS PART NUMBER FH-632-12ZI

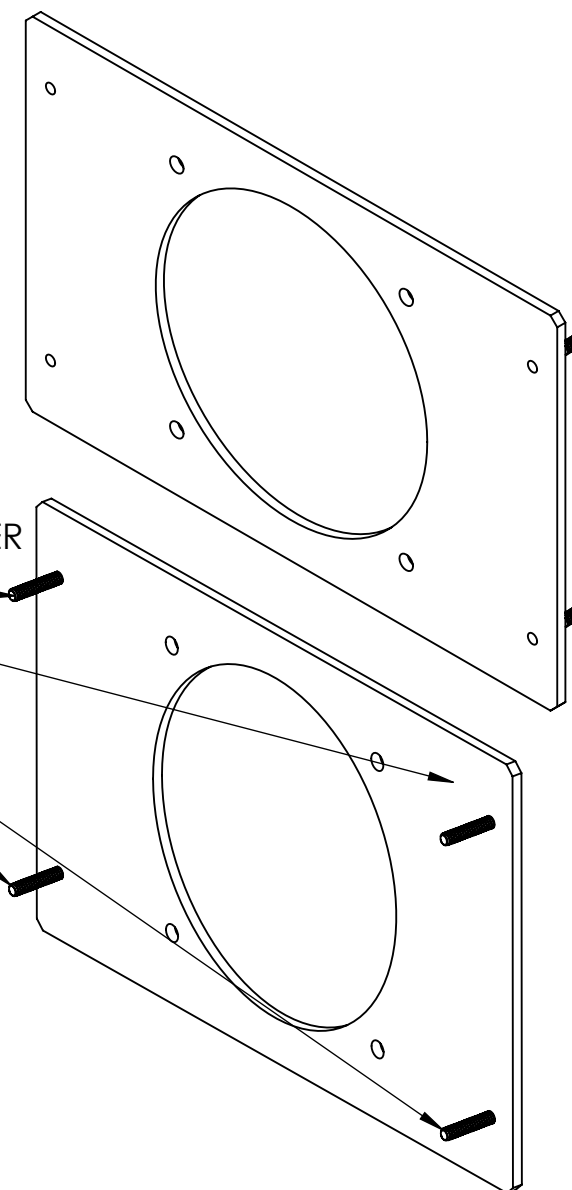
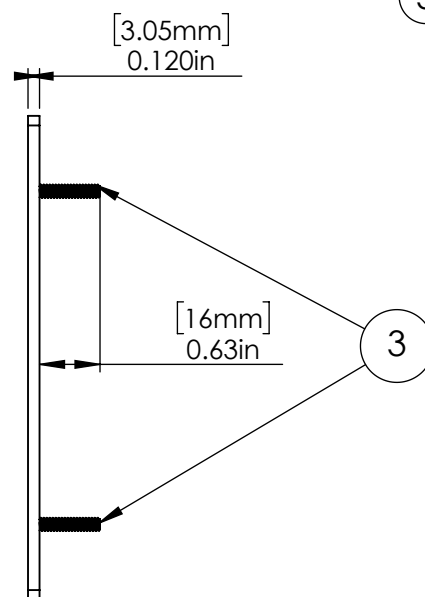
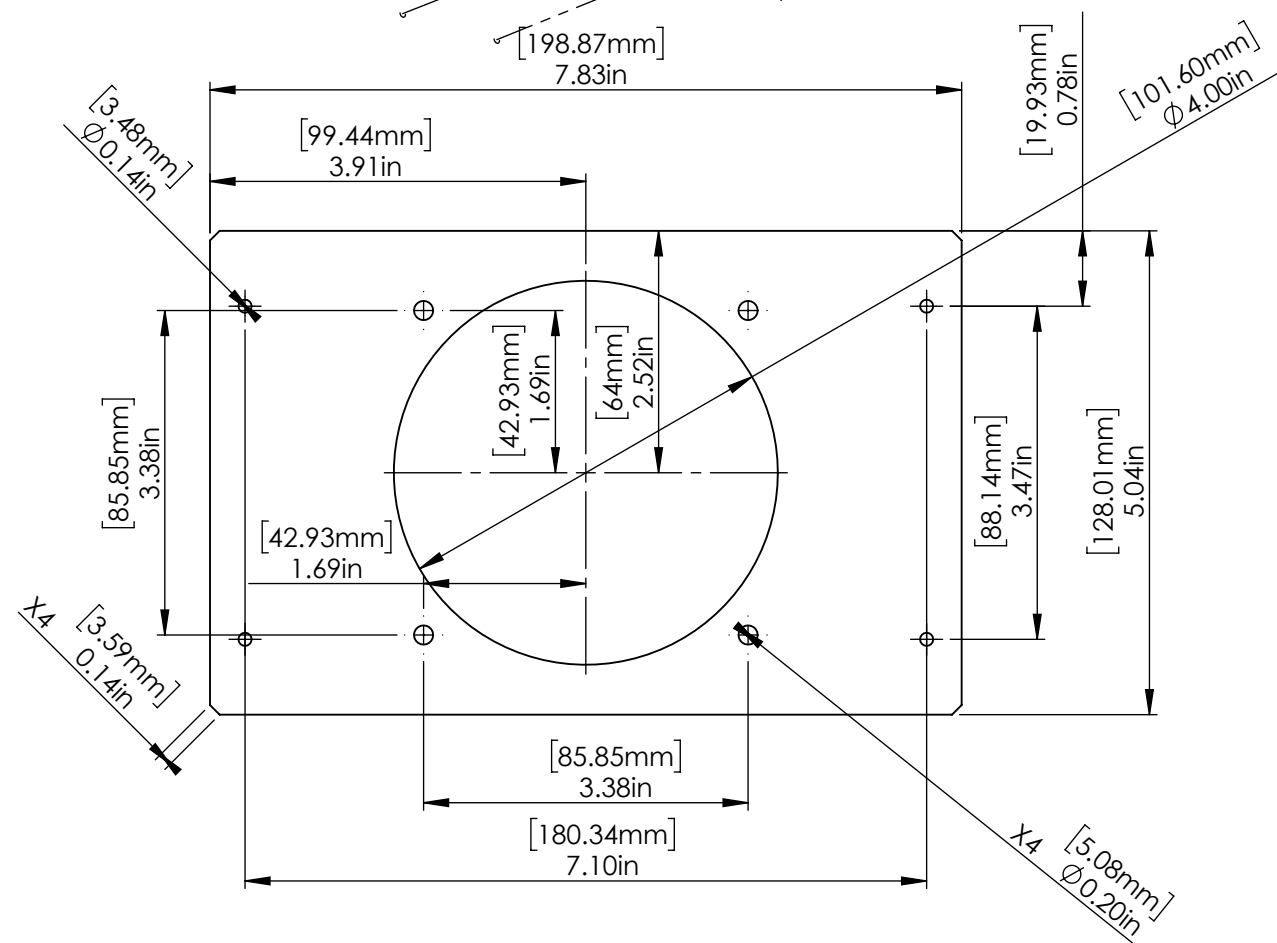

NOTE:
1. SURFACE FINISH/COLOR: ANSI 61 GREY (30-40)

SOLIDWORKS GENERATED DRAWING

THESE DRAWINGS AND SPECIFICATIONS ARE THE PROPERTY OF ELECTRO INDUSTRIES AND SHALL NOT BE REPRODUCED, COPIED, OR USED FOR MANUFACTURE OR SALE OF APPARATUS WITHOUT WRITTEN PERMISSION OF ELECTRO INDUSTRIES.



TOLERANCES AND SYMBOLY PER ANSI/AMSE Y14.5M-1994 DIMENSIONS SPECIFIED ARE AFTER ADDITIVE FINISH.

MATERIAL:

STEEL

TITLE: SHARK 200

DECIMALS
.XX ± 0.010
.XXX ± 0.005
for 1st 5 inches plus 0.001 each additional inch.)

ANGLES
XX ± 0.5°
XX.X ± 0.1°

SURF. FINISH
SEE NOTES

DRAWN BY: EM DATE: 3/29/19

ENGINEERING CHECK: TB DATE: 3/29/19

DOCUMENTATION CHECK: DS DATE: 3/29/19

TITLE DESCRIPTION:

PQMII TO SHARK 200 MOUNT ADAPTER PLATE

FOR DIMENSIONS NOT SHOWN USE DIGITAL DATA. FILE NAME: E145372-A-3-29-19.ZIP

SIZE	SCALE
B	DO NOT SCALE DRAWING

PART NUMBER: E145372

REV. NO	CHANGE ORDER	RELEASE DATE	SHEET
A	4900	3/29/19	1 OF 1

A

B

C

D

E